

# Cooperative organization in a macromolecular complex

Markus A Seeliger<sup>1,2</sup>, Sadie E Breward<sup>1,3</sup>, Assaf Friedler<sup>1</sup>, Oliver Schon<sup>1</sup> & Laura S Itzhaki<sup>1,3</sup>

**The mechanism of assembly of multiprotein complexes and the subsequent organization of activity are not well understood. Here we report the application of biophysical tools to investigate the relationship between structure and function in protein assemblies. We used as a model system the SCF<sup>Skp2</sup> complex that targets p27<sup>Kip1</sup> for ubiquitination and subsequent degradation; this process requires an adapter protein, Cks1. By dissecting the interactions between the different subunits we show that the properties of Cks1 are highly context dependent, and its activity is acquired only when the complex is fully assembled. The results provide insights into the central role of small adapters in macromolecular assembly and explain their high sequence conservation. Simultaneous and synergistic binding of multiple subunits in a complex provides the specificity and control required before the key cell-cycle regulator p27 is committed to degradation.**

The challenge in the postgenomic era is to understand how the information of the genome translates into biological function. One of the most striking findings of the genome projects is that the number of genes in *Caenorhabditis elegans* and in humans is of the same order of magnitude. Thus, more extensive networks of intermolecular interactions may account for the greater biological complexity of higher organisms<sup>1</sup>. Recently, the interactions of yeast proteins have been probed using genome-wide approaches and a complex network of interactions between multiprotein complexes has emerged from these investigations<sup>2–5</sup>. High resolution structural studies have also yielded insights into the function of large machines like the ribosome and RNA polymerase II, in which dozens of proteins interact with thousands of RNA bases to form a functional complex<sup>6–9</sup>. However, many assemblies may form only transiently or exhibit a dynamic subunit composition, and their function may change accordingly; therefore, to understand the fundamentals of protein complex function, one has to understand how they assemble. Large protein complexes are unlikely to assemble by random association. Instead, a specific order of assembly may exist, analogous to mechanisms of protein folding. Assembly may be further controlled *in vivo* by temporal and spatial coordination of protein expression and post-translational modification. To understand how macromolecular structure translates to function one will need also to determine the characteristics of a complex, how they differ from those of the individual components and the contribution of each subunit to the overall activity. Here we apply biophysical techniques to address the above questions using the ubiquitin ligation complex SCF<sup>Skp2</sup> as a model system.

Members of the Cks family of proteins are highly conserved in all eukaryotes and are required for controlled progression through the cell cycle. All Cks proteins share a canonical function in targeting the

cyclin regulatory subunit of cyclin-dependent kinase 2 (Cdk2) for degradation via the APC (anaphase promoting complex) ubiquitin ligation complex<sup>10,11</sup>. Human Cks1 has an additional and unique function in targeting the Cdk2 inhibitor p27<sup>Kip1</sup> for degradation via the SCF ubiquitin ligation complex<sup>12–15</sup>. All Cks proteins bind to Cdk2 via their four-stranded antiparallel  $\beta$ -sheet<sup>16</sup>. They also bind phosphopeptides via the so-called ‘phosphate-binding’ site located on the face of the  $\beta$ -sheet opposite to the Cdk2-binding site. A phosphorylated C-terminal peptide of p27 binds to Cks1 at this site<sup>13</sup>. Finally, the unique function of Cks1 was found to be attributable to a third binding site involving the two  $\alpha$ -helices of Cks1. Cks1 interacts through this binding site with the Skp2 subunit of the Skp–Cullin–F-box (SCF<sup>Skp2</sup>) ubiquitin ligase<sup>17</sup>.

In this study, we have used biophysical techniques and protein engineering to explain the results of the earlier biochemical study<sup>16</sup> and understand the functional mechanism of the Cks1 adapter in assembling SCF<sup>Skp2</sup> with its target p27. We find that the assembled complex of Cks1, Cdk2 and Skp1–Skp2 has markedly different properties from those of its individual parts: formation of the Cks1–Skp1–Skp2 complex increases the affinity of Cks1 for the p27 phosphopeptide more than 100-fold. Subsequent assembly of Skp1–Skp2-complexed Cks1 with Cdk2 further increases the affinity for the p27 phosphopeptide. Mutagenesis also reveals the long-range coupling between distant functional surfaces in Cks1 and underlines the cooperative organization of the assembly. The results provide insights into the role of molecular adapters that mediate between the different subunits of multiprotein complexes. The data show how adapter molecules could provide the means for achieving tight control in a critical and irreversible process such as the degradation of a key cell-cycle regulator.

<sup>1</sup>MRC Centre for Protein Engineering, Hills Road, Cambridge CB2 2QH, UK and Cambridge University Chemical Laboratory, Lensfield Road, Cambridge CB2 1EW, UK. <sup>2</sup>Current address: Howard Hughes Medical Institute, Department of Molecular and Cell Biology, Department of Chemistry, University of California, Berkeley, Berkeley, California 94720, USA. <sup>3</sup>Current address: MRC Cancer Cell Unit, Hutchison/MRC Research Centre, Hills Road, Cambridge CB2 2XZ, UK. Correspondence should be addressed to L.S.I. (l.s.i.10@cam.ac.uk).

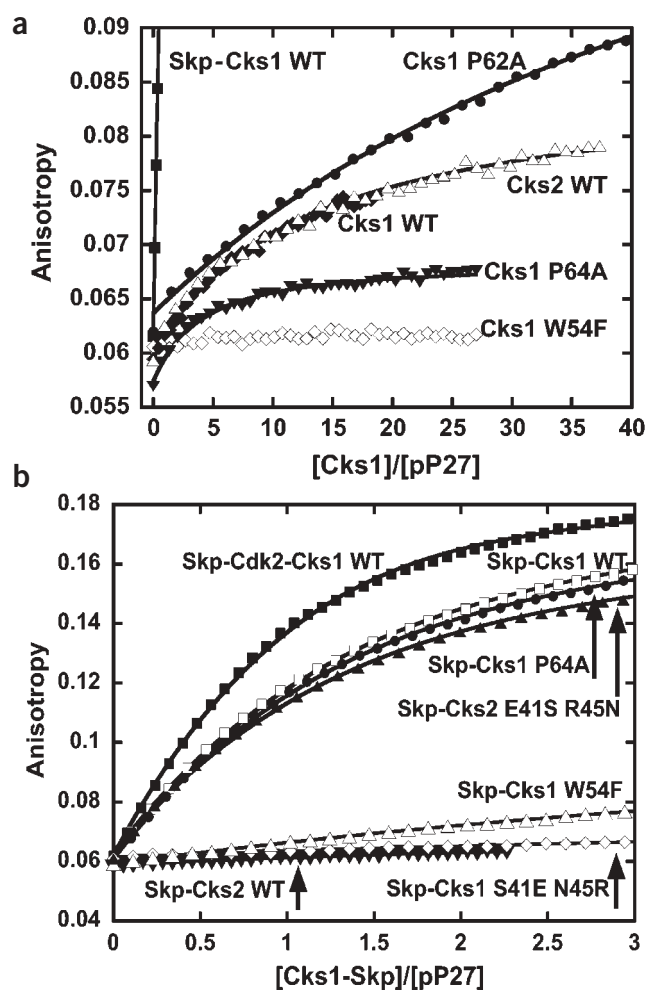

**Figure 1** Binding of fluorescein-labeled p27 phosphopeptide to Cks1.

(a) Fluorescence anisotropy titrations of mutant Cks proteins to fluorescein-labeled p27 phosphopeptide. Skp1-Skp2-Cks1 WT (■); Cks1 P62A (●); Cks1 WT (◆); Cks2 WT (△); Cks1 P64A (▼); Cks1 W54F (◇).

(b) Fluorescence anisotropy titration of Cks-Skp1-Skp2 complexes to fluorescein-labeled p27 phosphopeptide. The higher anisotropy values of the Cks1-Cdk2 complex are due to the higher mass of the complex. Skp1-Skp2 in complex with: Cks1 WT-Cdk2 (■); Cks1 WT (□); Cks1 P64A (●); Cks2 E41S R45N (▲); Cks1 W54F (△); Cks1 S41E N45R (◇); Cks2 WT (▼).

between the Skp1-Skp2 complex and Cks1 was observed by isothermal titration calorimetry (ITC) (Fig. 2 and Table 2). The  $K_d$  of 0.015  $\mu\text{M}$  is 100 $\times$  tighter than the interaction between Cks1 and Cdk2 (Fig. 2).

The high affinity allows the Cks1-Skp1-Skp2 complex to be pre-assembled and used subsequently in the anisotropy assay to determine the affinity of the complex for p27 phosphopeptide. A large increase in phosphopeptide binding affinity is observed when Cks1 is assembled with Skp1-Skp2 (0.47  $\mu\text{M}$ ) compared with free Cks1 ( $K_d = 70 \mu\text{M}$ ) (Fig. 1a and Table 2). Moreover, Cks1 is necessary for tight binding, as Skp1-Skp2 alone did not bind phosphopeptide (Table 2). It could be that complex formation renders one of the binding partners in a high-affinity state, but that the static assembly of the complex is not in itself necessary for tight binding. To address this, phosphopeptide binding experiments were done with Cks2 (which does not form a stable complex with Skp1-Skp2; ref. 13) in the presence of Skp1-Skp2. Weak affinity of Cks2 for p27 phosphopeptide was observed in the presence of Skp1-Skp2 (Table 3 and Fig. 1b), with a  $K_d$  of 55  $\mu\text{M}$  that is the same within error as that observed for Cks2 alone (80  $\mu\text{M}$ ). Thus, it is the ability of Cks1 to form a stable complex with Skp1-Skp2 that enables tight binding of phosphopeptide.

### Binding of Cdk2 further increases p27 affinity

Recent studies have highlighted a controversy over the role of Cdk2 in the interaction between Cks1-Skp1-Skp2 and p27 (refs. 12,13). Biochemical studies showed that an interaction between Cks1 and Cdk2 is required for the stimulation of ubiquitin ligation to p27 by SCF<sup>Skp2</sup> (ref. 17). There are at least two ways for Cdk2 to enable a tight interaction between p27 and Cks1-Skp1-Skp2. In the first, Cdk2 binds both Cks1 and p27 and acts as a physical bridge. Alternatively, Cdk2 increases the affinity of Cks1 for p27 by crosstalk between the binding

## RESULTS

### Binding of Cks proteins to p27 phosphopeptide is weak

A fluorescein-labeled phosphopeptide corresponding to the C-terminal 19 residues of p27 was used to investigate the interactions between Cks proteins and p27. The peptide was shown previously to interact with the human Cks proteins<sup>13</sup>. Fluorescence anisotropy was used to monitor binding of the proteins to the fluorescein-labeled p27 phosphopeptide, with an increase in anisotropy indicating binding. Fluorescein labeling did not affect the interaction (see Methods).

The two human Cks proteins, Cks1 and Cks2, bind the peptide with affinities of 70  $\mu\text{M}$  and 80  $\mu\text{M}$ , respectively (Fig. 1a and Table 1). These affinities are ten times greater than that of the only other Cks-phosphosubstrate interaction measured previously, that between Suc1 (the Cks from *Schizosaccharomyces pombe*) and a phosphopeptide derived from *cdc25* (ref. 18); nevertheless they are still weak. Suc1 and the Cks protein from *Saccharomyces cerevisiae* (sCks1) bind the phosphopeptide with affinities in a similar range ( $K_d$  values of 310  $\mu\text{M}$  and 90  $\mu\text{M}$ , respectively; Table 1).

### Skp1-Skp2 binding increases Cks1 affinity for p27

Recently the Skp1-Skp2 complex was found to increase the affinity of Cks1 to the p27 phosphopeptide<sup>17</sup>. To quantify the effect, we reconstituted and characterized the ternary complex between Cks1 and Skp1-Skp2. Analytical gel filtration shows that the complex remains intact over the timescale of our binding experiments. A very tight association

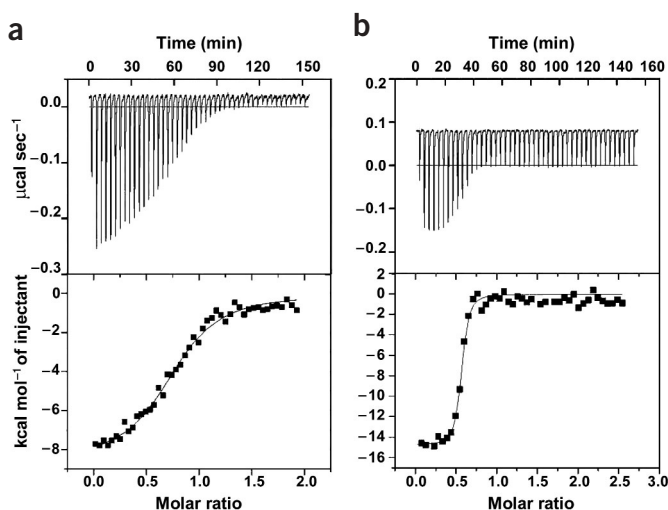

**Figure 2** Binding of Cks1 to Cdk2 (left) and Cks1 to Skp1-Skp2 (right). Binding was measured by ITC.

sites within the Cks1 molecule. To investigate these possibilities, we quantified the interaction of Cks1 with Cdk2 and of the Cks1–Cdk2 complex with the p27 phosphopeptide.

First, we measured the affinities of Cdk2 for free Cks1 and for the Cks1–Skp1–Skp2 complex. Cdk2 binds to free Cks1 (Fig. 2) and to Cks1 in complex with Skp1–Skp2 with similar affinities ( $K_d$  values of 1.5  $\mu$ M and 2.6  $\mu$ M, respectively). Further, Cdk2 alone does not bind to the p27 phosphopeptide (Table 1), ruling out a bridging role for Cdk2. We next reconstituted the complex of Cdk2–Cks1–Skp1–Skp2 and determined its affinity for p27 phosphopeptide. We find that the additional presence of Cdk2 in the complex increases the affinity for phosphopeptide approximately three-fold ( $K_d = 0.15 \mu$ M compared with 0.47  $\mu$ M; Table 3 and Fig. 1b). This effect occurs only in the context of the high-affinity Skp1–Skp2-bound form of Cks1; in contrast, there is no effect of Cdk2 binding on phosphopeptide affinity of the low-affinity, Skp-free form of Cks1: the complex of Cks1 and Cdk2 binds phosphopeptide in the absence of Skp1–Skp2 with a  $K_d$  similar to that of Cks1 alone ( $K_d$  values of 120  $\mu$ M and 70  $\mu$ M, respectively; Table 1).

### Crosstalk between binding sites

The role of individual residues in Cks1 in the binding of phosphopeptide was addressed by making mutations throughout the molecule (Table 1 and Fig. 3). Mutations were designed to disrupt the proposed p27 (phosphate-binding) site (Lys11, Arg20, Trp54, Arg71), in the Cdk2-binding loop between  $\beta$ 3 and  $\beta$ 4 (residues 60–65), and in the  $\alpha$ -helical region (residues 29–45) (Fig. 3a). Mutations were also designed elsewhere in order to identify possible long-range effects that might act indirectly on the binding sites.

Mutations in the phosphate-binding site increase the dissociation constants from the wild-type value of 70  $\mu$ M to >500  $\mu$ M (K11A, W54F). The deletion of the phenyl group of Tyr8, located close to Lys11 in  $\beta$ -strand 1, increases the  $K_d$  to 600  $\mu$ M, suggesting a role of this residue also in the binding of peptides to the phosphate-binding site.

A number of mutations were made in the Cdk2-binding loop, located between  $\beta$ 3 and  $\beta$ 4. P62A and E63P decrease the affinity for phosphopeptide four- and five-fold ( $K_d$  of 340  $\mu$ M and 290  $\mu$ M, respectively), although E63A, E63G and E63Q have only minor effects on the affinity (Table 1 and Fig. 3b). Most notably, the mutation P64A increases the affinity three-fold relative to wild type ( $K_d$  of 20  $\mu$ M). Thus, mutations in the Cdk2-binding loop change the affinity up to 17-fold, from a  $K_d$  of 20  $\mu$ M for P64A to 340  $\mu$ M for P62A. These results are surprising because the loop is distant in the structure from the phosphate-binding site. However, they are consistent with our previous findings of long-range communication between binding sites for the *S. pombe* homolog Suc1: it was shown that a change of the conformation in the Cdk2-binding loop in Suc1 alters its affinity for phosphorylated substrates<sup>19</sup>. The observation has been interpreted as an indication of signal transduction between different parts of the structure.

The human Cks proteins exhibit a sequence identity of 81% and therefore the differences in biological activity must be attributable to a very small number of amino acid substitutions. The least conserved regions are the two short  $\alpha$ -helices (Fig. 3a), and this region was recently identified as the Skp2-binding site<sup>17</sup>. We replaced each surface helix residue in Cks1 (positions 26, 27, 29, 31, 41 and 45), and other nonconserved surface residues (positions 13, 16 and 52), with the corresponding residues in Cks2 and monitored the effect on phosphopeptide binding (Table 1). Whereas wild-type Cks1 and Cks2 bind phosphopeptide with a similar affinity, exchange of single amino acid

**Table 1** Binding of Cks proteins to p27 phosphopeptide measured by fluorescence anisotropy

Protein	$K_d$ ( $\mu$ M)	$\Delta G_{U-F}$ (kcal mol <sup>-1</sup> )
Cks1 WT	70 $\pm$ 10	4.1 $\pm$ 0.2
Cks2 WT	80 $\pm$ 10	2.5 $\pm$ 0.1
sCks WT	90 $\pm$ 10	6.2 $\pm$ 0.1
Suc1 WT	310 $\pm$ 30	7.1 $\pm$ 0.1
Cdk2–Cks1	120 $\pm$ 30	–
Cdk2	>1,500	–
<b>Phosphate-binding site mutants</b>		
Y8A	600 $\pm$ 70	3.5 $\pm$ 0.2
K11A	>1,500	4.6 $\pm$ 0.2
W54F	>1,500	2.7 $\pm$ 0.1
P62A R20K	>1,500	–
<b>Cdk2-binding loop mutants</b>		
P62A	340 $\pm$ 50	5.4 $\pm$ 0.3
E63A	120 $\pm$ 20	4.4 $\pm$ 0.2
E63G	120 $\pm$ 20	4.0 $\pm$ 0.2
E63P	290 $\pm$ 50	2.9 $\pm$ 0.1
E63Q	190 $\pm$ 30	3.6 $\pm$ 0.2
P64A	20 $\pm$ 5	3.7 $\pm$ 0.2
<b>Skp2-binding site mutants</b>		
E16H A29S L31Q	150 $\pm$ 20	2.6 $\pm$ 0.1
L31Q	110 $\pm$ 20	3.1 $\pm$ 0.2
A29S L31Q	300 $\pm$ 50	2.5 $\pm$ 0.1
S41E	150 $\pm$ 20	4.0 $\pm$ 0.2
S41E N45R	170 $\pm$ 30	3.6 $\pm$ 0.2
N45R	120 $\pm$ 20	3.7 $\pm$ 0.2
<b>Other sites</b>		
I6V	80 $\pm$ 10	3.7 $\pm$ 0.2
S9A	60 $\pm$ 10	3.7 $\pm$ 0.2
SG9	110 $\pm$ 20	4.0 $\pm$ 0.2
D13F E16H	60 $\pm$ 10	4.0 $\pm$ 0.2
K26R D27E	320 $\pm$ 50	3.8 $\pm$ 0.2
E18A	100 $\pm$ 15	2.9 $\pm$ 0.1
V32A	160 $\pm$ 20	3.0 $\pm$ 0.1
S39A	100 $\pm$ 10	3.3 $\pm$ 0.2
S51A	170 $\pm$ 30	4.0 $\pm$ 0.2
Q52L	60 $\pm$ 10	3.1 $\pm$ 0.2
V55A	110 $\pm$ 20	3.0 $\pm$ 0.2
M58L	210 $\pm$ 30	3.6 $\pm$ 0.2
H65A	180 $\pm$ 30	3.5 $\pm$ 0.2

Experiments were done at 10 °C in 50 mM Tris-HCl buffer pH 7.5, 1 mM EDTA.  $\Delta G_{U-F}$  is the free energy of unfolding, determined for the Cks proteins by urea-induced equilibrium denaturation experiments<sup>32</sup> at 10 °C for Cks1 and Cks2 and at 25 °C for Suc1 and sCks. WT, wild type.

pairs in Cks1 substantially weakens the affinity for phosphopeptide and the double mutant A29S L31Q binds with four times lower affinity than does the wild type. Secondary effects on the binding affinity, such as the misfolding of unstable mutant proteins, can be excluded as all Cks1 mutants used in these assays have thermodynamic stabilities that are at least equal to that of wild-type Cks2 (Table 1).

### Two amino acid substitutions lead to gain of function in Cks2

We looked at the phosphopeptide affinity of two double mutants in the Skp2-binding site, S41E N45R (helix 2) and A29S L31Q (helix 1), in the presence of Skp1–Skp2. A very low affinity for the phosphopeptide was indeed observed for S41E N45R (Fig. 1b and Table 3). In contrast, the double mutant A29S L31Q has a  $K_d$  of 0.5  $\mu$ M, similar to that of wild-type Cks1. The results confirm the previous identification of

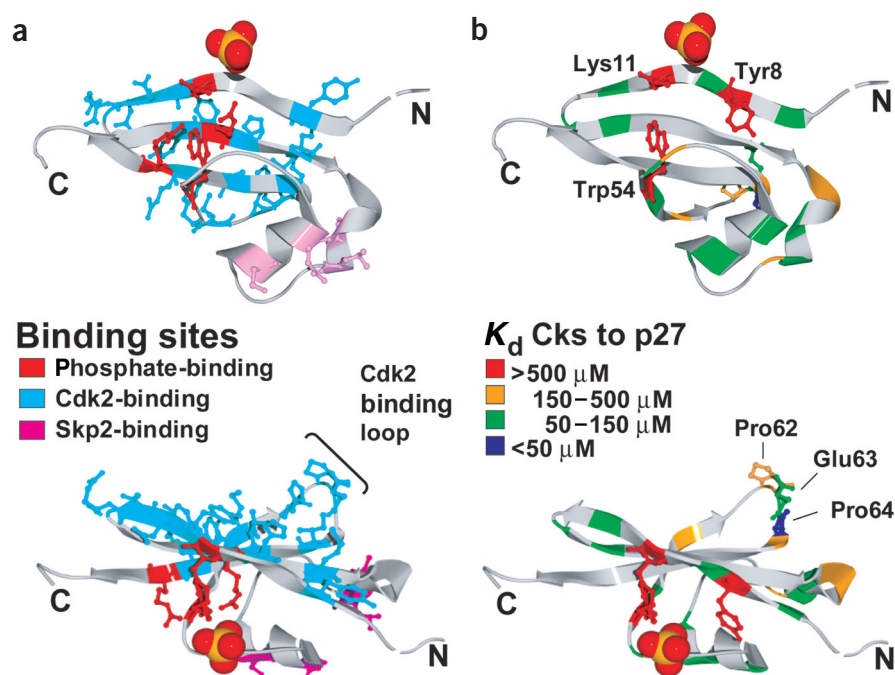

**Figure 3** Location of the three binding sites on Cks1 and effect of mutations in Cks1 on the affinity for p27 phosphopeptide. (a) Location of the three binding sites on Cks1. The crystal structure of Cks1 with phosphate ion bound was used. The location of the Cdk2-binding loop is also shown. (b) Effect of mutations in Cks1 on the affinity for p27 phosphopeptide color coded on the ribbon diagram of the Cks1 structure<sup>31</sup>. Those residues are shown for which mutation had the largest effect on p27 phosphopeptide binding. Mutation of residues Tyr8, Arg11 and Trp54 in the phosphate-binding site lowered binding affinity. Mutation of residues in the Cdk2-binding loop resulted in both the highest affinity for phosphopeptide (P64A,  $K_d = 20 \mu\text{M}$ ) and the lowest affinity (P62A,  $K_d = 340 \mu\text{M}$ ; E63P,  $K_d = 290 \mu\text{M}$ ) of any residue outside the phosphate-binding site. Mutation of blue residues,  $K_d < 50 \mu\text{M}$ ; green residues,  $50 \mu\text{M} < K_d < 150 \mu\text{M}$ ; orange residues,  $150 \mu\text{M} < K_d < 500 \mu\text{M}$ ; red residues,  $K_d > 500 \mu\text{M}$ .

the key role of residues Ser41 and Asn45 of Cks1 in binding to Skp1-Skp2 (ref. 17).

This finding raises the question of whether the introduction of these two amino acids in Cks2 is sufficient for complex formation with Skp2 and high-affinity binding of phosphopeptide. Indeed, we find that the mutant Cks2 protein E41S R45N binds phosphopeptide in the presence of Skp1-Skp2 with the same affinity ( $K_d = 0.48 \mu\text{M}$ ) as wild-type Cks1 (Fig. 1b and Table 3).

#### p27 binds same site on high- and low-affinity Cks1

Mutations in the phosphate-binding site in the free form of Cks1 disrupt interactions with the phosphopeptide; however, mutation of charged or polar side chains in this region increases the tendency to aggregate. Therefore, a stable phosphate-binding site mutant was engineered—a double mutant combining R20K in the phosphate-binding site and P62A that was found previously to have enhanced thermodynamic stability and better solubility. Binding to the phosphopeptide is disrupted by the double mutation P62A R20K, as the  $K_d$  is greater than can be detected by the anisotropy assay (Table 1). The phosphopeptide affinity is disrupted by this mutation in Skp-bound Cks1 also (Table 3), indicating that p27 phosphopeptide binds to the same region of Cks1 in both its free (low-affinity) and complexed (high-affinity) forms.

#### Effect of mutation in low- versus high-affinity Cks1

Binding of the phosphopeptide to free Cks1 is altered by mutations in the distant Cdk2-binding loop and we have rationalized this as crosstalk between binding sites. To test whether this crosstalk is also present in Skp-bound Cks1, we measured the p27-binding affinities of selected mutants in the context of the complex. The effects of mutation were much less pronounced in the complex: the affinities of the complexed Cks1 mutants for p27 phosphopeptide were similar to that of the complexed wild-type Cks1 (Table 3 and Fig. 1b). Only the mutation of glutamate to alanine at position 63 decreased the  $K_d$  slightly ( $0.27 \mu\text{M}$ ), but the mutation to glutamine at the same position showed wild-type affinity ( $K_d = 0.49 \mu\text{M}$ ).

#### DISCUSSION

Here we provide a quantitative biophysical study of the interactions within a multiprotein complex (Fig. 4 and Table 2). The results rationalize the findings of the earlier biochemical study<sup>17</sup>, which showed that all three binding sites of Cks1 are required to promote ubiquitin ligation of p27; the biophysical analysis reveals that the binding sites are interdependent and this cooperative organization means that activity is only gained upon full assembly of the complex. The functional difference between Cks1 and Cks2 lies in the ability to bind to Skp2 and thereby promote p27 binding. The finding that only two substitutions (at positions 41 and 45) account for this difference tempts us to speculate that a gain-of-function mutation like E41S R45N in Cks2 may be the cause of p27 depletion in a subset of human

**Table 2** Context dependence in the Cks1 assembly: coupling between the different subunit interactions

Protein or protein complex	Binding partner	$K_d$ ( $\mu\text{M}$ ) <sup>a</sup>	$\Delta G$ (kcal mol <sup>-1</sup> )	Strength of binding relative to binding of Cks1 alone
Cks1	p27	<b>70</b>	5.4	1
Cks1-Skp2	p27	<b>0.47</b>	8.2	149
Cks1-Cdk2	p27	<b>120</b>	5.1	0.6
Cks1-Cdk2-Skp2	p27	<b>0.15</b>	8.8	467
Cks1	Skp2	<b>0.014</b>	10.2	1
Cks1-Cdk2	Skp2	0.07	9.3	0.2
Cks1-p27	Skp2	0.0001	13	140
Cks1-Cdk2-p27	Skp2	0.0001	13	140
Cks1	Cdk2	<b>1.5</b>	7.5	1.0
Cks1-Skp2	Cdk2	8	6.6	0.2
Cks1-p27	Cdk2	3	7.2	0.5
Cks1-Skp2-p27	Cdk2	<b>2.6</b>	7.2	0.6

<sup>a</sup>Affinities that were directly measured are in bold; the other affinities were calculated using the thermodynamic cycles.

**Table 3 Binding of Cks–Skp2–Skp1 complexes to p27 phosphopeptide measured by fluorescence anisotropy**

Description of experiment	Skp2–Skp1 in complex with:	$K_d$ ( $\mu\text{M}$ )
	Cks1 WT	$0.47 \pm 0.05$
	Cks2 WT	$55 \pm 15$
Effect of mutation in phosphate-binding site	Cks1 P62A R20K	$33 \pm 8$
	Cks1 W54F	$7.7 \pm 1.8$
	Cks1 R71K	$0.46 \pm 0.05$
Effect of mutation in Skp2-binding site	Cks1 A29S L31Q	$0.5 \pm 0.05$
	Cks1 S41E N45R	$14 \pm 3$
Effect of amino acid substitution in Cks2	Cks2 E41S R45N	$0.48 \pm 0.05$
Effect of mutation in Cdk2-binding loop	Cks1 P62A	$0.39 \pm 0.04$
	Cks1 E63A	$0.27 \pm 0.03$
	Cks1 E63Q	$0.49 \pm 0.05$
	Cks1 P64A	$0.43 \pm 0.04$
Effect of Cdk2 on p27 binding	Cks1 WT and Cdk2	$0.15 \pm 0.02$

No detectable binding was observed for Skp2–Skp1 to p27 phosphopeptide. WT, wild type.

tumors. This would provide an alternative mechanism to Cks1 over expression<sup>15</sup>.

### Cks1 as a Skp2 adapter

The unique biological function of human Cks1 is defined by its ability to bind the Skp2 component of the SCF<sup>Skp2</sup> complex<sup>12,13</sup>. Cks1 binds very tightly to Skp1–Skp2, with a  $K_d$  of  $0.015 \mu\text{M}$ , roughly 100-fold tighter than the binding of Cks1 to Cdk2 ( $K_d = 1.5 \mu\text{M}$ ), even though the binding site for Cdk2 constitutes the much larger surface of Cks1. As judged by both sequence conservation and biological role, Cks2 is evolutionarily more closely related to the other members of the Cks family than Cks1. Thus, Cks2 seems to be the ‘canonical’ Cks protein in humans. The finding that the expression of Cks1 alternates throughout the cell cycle in parallel with Skp2 (ref. 17), together with the very tight affinity identified in our study suggests that Cks1 is permanently attached to Skp2 rather than Cdk2.

### Crosstalk between binding sites

Long-range energetic couplings in Cks1 are revealed when we perturb the protein by mutation and by binding. For example, mutations in the Cdk2-binding loop of Cks1 alter the affinity of the p27 phosphopeptide-binding site. The disruption of p27 binding by mutation at distant sites is mirrored by the reduced p27 ubiquitin-ligation efficiency of the mutants measured in the earlier biochemical study<sup>17</sup>. Such communication between distant functional surfaces is likely to be important for signal transduction, allostery and functional specificity<sup>20–23</sup>. The complexity of these effects is highlighted by the observation that they are dependent on intermolecular context. In contrast to free Cks1, Skp1–Skp2-bound Cks1 is much less sensitive to mutation: the same mutations have no effect or only very little effect on affinity for p27 phosphopeptide.

### Enhanced p27 affinity in the Cks1–Skp1–Skp2 complex

Skp1–Skp2-complexed Cks1 binds p27 phosphopeptide >100-fold tighter than does free Cks1. Three nonexclusive models could explain

this. (i) Binding of Cks1 to Skp2 creates a bimolecular binding site adjacent to the Cks–Skp2 binding interface. (ii) Cks1 induces structural changes in Skp2. (iii) Skp2 binding induces structural changes in Cks1. Our results oppose the third model. First, the NMR spectra of free and Skp1–Skp2-complexed Cks1 overlay perfectly (data not shown), indicating that Skp2 binding does not alter the structure of Cks1. Second, the Cks1–Skp1–Skp2 complex binds Cdk2 with an affinity close to that of free Cks1; because the Cdk2-binding interface on Cks1 constitutes the entire middle of the  $\beta$ -sheet, any major structural rearrangements induced by Skp2 would be expected to lead to a substantial change in Cdk2 affinity. The data for the mutants strongly point to the first model, in which both Cks1 and Skp2 interact directly with p27: mutations in the phosphate-binding site of Cks1 disrupt the high-affinity interaction between Skp2-bound Cks1 and p27 phosphopeptide. This indicates a direct interaction between Cks1 and p27 rather than an interaction bridged by Skp2.

### Origins of long-range signaling in Cks1

It has been proposed that Cks proteins function as signal transducers, whereby Cdk2 binding to Cks modulates the affinity for other substrates<sup>19</sup>. Here we find that Cdk2 binding does not change the affinity of free Cks1 for p27 phosphopeptide, but it does increase the affinity of the Cks1–Skp1–Skp2 complex for the phosphopeptide three-fold. The three-fold effect is modest when compared with the likely large effect of simultaneous tight binding of Cdk2 to both the Cks1–Skp1–Skp2 complex and to full-length p27; however, even small effects may contribute to the high affinity and specificity of this complex assembly. An alternative explanation may be that in the context of the SCF<sup>Skp2</sup> pathway the effect is modest but that it is greater in a different context such as the APC pathway.

The change in phosphopeptide affinity upon binding of Cks1 to Cdk2 is a further illustration of the crosstalk between distant binding sites in the Cks proteins. A striking feature of Cks is that the signal

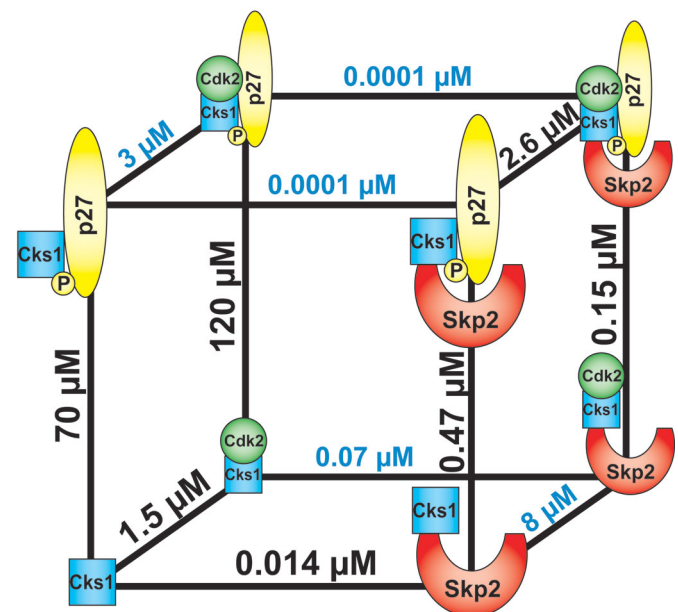

**Figure 4** Context-dependent signaling by the Cks1 adapter protein. The vertical axis represents complex formation of Cks1 (light blue) with the p27 subunit (yellow); the horizontal axis, the Skp2(–Skp1) subunit (red); and the axis perpendicular to the plane of the paper, the Cdk2 subunit (green). Black numbers, affinities determined experimentally; the other affinities were calculated using the thermodynamic cycles.

from Cdk2 binding does not appear to trigger a structural change (the crystal structures of free and Cdk2-bound forms of Cks1 are highly superimposable)<sup>16</sup>. So what gives rise to the three-fold increase in affinity for p27 phosphopeptide, and why do we see it only in Skp2-bound Cks1 and not in free Cks? NMR data (M.A.S., S.E.B., M. Bycroft, S.M.V. Freund & L.S.I., unpublished data) suggest that this crosstalk has its origins in the dynamic properties of the protein: the central strand  $\beta$ 4 of the sheet in Cks1 can be exchanged between two monomers to form a domain-swapped dimer<sup>24</sup> and NMR reveals that this strand is highly dynamic in the free form of the protein. Binding of Cdk2 on one face of the  $\beta$ -sheet of Cks1 greatly alters its dynamic behavior; the changes are not localized to the Cdk2-binding site but are propagated throughout the protein to distant sites including the phosphate-binding site. The subtle change in the phosphopeptide affinity upon Cdk2 binding might not be detectable in the low-affinity state of free Cks1, but it becomes apparent in the context of the high-affinity Skp1-Skp2-bound Cks1.

### Evolution of adapter molecules

There is likely to be high evolutionary pressure on adapter or scaffold molecules like Cks1, particularly at surface positions<sup>25</sup>, and consistent with this there is very high sequence identity in the Cks family. Moreover, the coupling of the multiple binding surfaces places further evolutionary pressure on these molecules as it increases the likelihood that a single mutation could disrupt the formation of the entire complex and thereby render all the partners inactive<sup>22,23</sup>. In contrast there will be little evolutionary pressure on the thermodynamic stability of adapters as they are wedged between other proteins within complexes and stabilized thereby. Indeed, the free energy of unfolding of free Cks1 is low ( $\sim 4$  kcal mol<sup>-1</sup>, as compared with  $\sim 8$  kcal mol<sup>-1</sup> for Suc1) but is more than compensated by the free energy of binding to any one of its three ligands (for example,  $\sim 8$  kcal mol<sup>-1</sup> for binding to Skp1-Skp2) (Table 2).

The canonical function of the Cks proteins is also as an adapter in the ubiquitin-mediated degradation of cyclins by the APC at the end of M-phase. Although both the canonical Cks function and the unique Cks1 function are within the same biological context of protein degradation via the ubiquitin pathway, there is a profound difference between the two: the ubiquitination target is a Cdk activator in one and a Cdk inhibitor in the other. The details of signal transduction by the Cks protein within each of the ubiquitin ligation assemblies are also different. The evolution of the human Cks family illustrates how the greater complexity of higher organisms may be achieved, not by a greater number of genes, but rather by a more extensive network of intermolecular interactions.

### METHODS

**Protein expression and purification.** Cks1, Cks2 and the Cks protein from *S. cerevisiae* were expressed and purified as described previously<sup>24</sup>. Suc1 was expressed and purified as described<sup>26</sup>. Proteins were judged by mass spectroscopy and SDS-PAGE to be >95% pure. Site-directed mutagenesis was carried out using the QuikChange kit (Stratagene). The thermodynamic stability of Cks wild-type and mutant proteins was determined by chemical denaturation as described<sup>24</sup>. The pGEX6P (Amersham) plasmid coding for the full-length human Cdk2 fused to a PreScission protease restriction site and glutathione S-transferase (GST) was a gift from J. Endicott (University of Oxford, Oxford, UK). Expression and purification of Cdk2 were carried out as described previously<sup>27</sup>. Plasmid (pGEX4T1, Amersham) coding for full-length Skp1 and Skp2 was a gift of A. Hershko (Technion, Haifa, Israel). The proteins are encoded as a dicistronic message with Skp2 fused to GST preceding Skp1 (refs. 28,29). Expression and purification were carried out as described<sup>28,29</sup>.

**Peptide synthesis.** The sequence of the peptide corresponding to the 19 residues of the C terminus of p27<sup>Kip1</sup> was: NAGSVEQ(pT)PKKPLGRQT. The phospho-threonine corresponds to residue 187 of p27. The peptide was synthesized with a phosphorylated threonine incorporated at the required position in the sequence, and purified as described<sup>30</sup>. The fluorescein-labeled phosphopeptide was synthesized by G. Bloomberg (University of Bristol, Bristol, UK).

**Binding experiments monitored by fluorescence anisotropy.** All anisotropy studies were done with fluorescein-labeled p27 phosphopeptide at 10 °C on a Perkin Elmer LS55 luminescence spectrophotometer equipped with a Hamilton Microlab M dispenser. Peptide was dissolved in 50 mM Tris-HCl buffer, pH 7.5, 1 mM EDTA, filtered and degassed. To 900  $\mu$ l of the peptide solution in the cuvette, 240  $\mu$ l of the degassed and filtered protein solution was titrated in 40 injections. After each injection the solution was stirred for 30 s and incubated for a further 30 s. Fluorescence anisotropy was measured for excitation at 480 nm (bandwidth 15 nm) and emission at 530 nm (bandwidth 15 nm) with an integration time of 5 s. For binding studies with free Cks protein, we used peptide solution at 5  $\mu$ M and protein solutions in the syringe of  $\sim 500$   $\mu$ M. For the binding studies with complexed Cks, the complexes were performed by adding the binding partners in excess of Cks followed by incubation for at least 30 min at 10 °C. Peptide (0.5  $\mu$ M) and complexed Cks ( $\sim 5$   $\mu$ M) were subsequently used. Control experiments were done under identical concentrations but without Cks. Data were fit by laboratory software to an equation assuming 1:1 binding of Cks1 to peptide. Each experiment was repeated at least once.

**Fluorescein-labeled and unlabeled p27 phosphopeptide bind with similar affinities.** In this study, binding was measured by the change of anisotropy of the fluorescein-labeled phosphopeptide. The assay has the high sensitivity necessary for detection of  $K_d$  values in the submicromolar range, but it requires the use of a fluorescein label. To investigate the effect of the label, binding of unlabeled phosphopeptide to the Cks1-Skp1-Skp2 complex was measured using a competition experiment between unlabeled phosphopeptide and labeled phosphopeptide<sup>30</sup>. We monitored binding to the Cks1-Skp1-Skp2 complex rather than to free Cks1 because the higher affinity of the complex for phosphopeptide means that the affinity can be determined more accurately, that the binding detected is likely to be more specific and that only low concentrations of peptides are required. The unlabeled peptide bound to the complex with a  $K_d$  of  $1.0 \pm 0.3$   $\mu$ M, which is in good agreement with the  $K_d$  of the labeled peptide of 0.45  $\mu$ M justifying the use of the labeled peptide. The concentration of fluorescein-labeled peptide can be determined spectroscopically with much higher accuracy than that of unlabeled peptide, which may contribute to the difference in apparent affinities of labeled and unlabeled peptide.

**Isothermal titration calorimetry.** The binding affinities of Cks1 to Cdk2 and to the Skp1-Skp2 complex were determined by titration of Cks1 to Cdk2 and to Skp1-Skp2 at 10 °C using a MicroCal VP instrument (MicroCal). Protein solutions were dialyzed extensively in 50 mM Tris-HCl buffer, pH 7.5, 1 mM DTT, filtered and degassed before measurement. The instrument was operated according to the instructions of the manufacturer and data were analyzed by MicroCal Origin software.

### ACKNOWLEDGMENTS

We thank D. Vesprincev for help with running the experiments, A. Hershko, M. Bycroft and S. Teichmann for helpful discussions, and B. Schulman and J. Endicott for providing clones. This work was supported by the Medical Research Council of the UK (MRC). L.S.I. was supported by a Career Development Award from the MRC, M.A.S. by an External Research Studentship from Trinity College, Cambridge, UK, and A.F. by a Human Frontier Science Program long-term fellowship.

### COMPETING INTERESTS STATEMENT

The authors declare that they have no competing financial interests.

Received 22 January; accepted 11 July 2003

Published online at <http://www.nature.com/naturestructuralbiology/>

- Lander, E.S. *et al.* Initial sequencing and analysis of the human genome. *Nature* **409**, 860–921 (2001).
- Uetz, P. *et al.* A comprehensive analysis of protein-protein interactions in *Saccharomyces cerevisiae*. *Nature* **403**, 623–627 (2000).
- Ito, T. *et al.* A comprehensive two-hybrid analysis to explore the yeast protein interactome. *Proc. Natl. Acad. Sci. USA* **98**, 4569–4574 (2001).
- Gavin, A.C. *et al.* Functional organization of the yeast proteome by systematic analysis of protein complexes. *Nature* **415**, 141–147 (2002).
- Ho, Y. *et al.* Systematic identification of protein complexes in *Saccharomyces cerevisiae* by mass spectrometry. *Nature* **415**, 180–183 (2002).
- Cramer, P., Bushnell, D.A. & Kornberg, R.D. Structural basis of transcription: RNA polymerase II at 2.8 Å resolution. *Science* **292**, 1863–1876 (2001).
- Gnatt, A.L., Cramer, P., Fu, J., Bushnell, D.A. & Kornberg, R.D. Structural basis of transcription: an RNA polymerase II elongation complex at 3.3 Å resolution. *Science* **292**, 1876–1882 (2001).
- Yonath, A. The search and its outcome: high-resolution structures of ribosomal particles from mesophilic, thermophilic, and halophilic bacteria at various functional states. *Annu. Rev. Biophys. Biomol. Struct.* **31**, 257–273 (2002).
- Ramakrishnan, V. Ribosome structure and the mechanism of translation. *Cell* **108**, 557–572 (2002).
- Patra, D. & Dunphy, W.G. Xe-p9, a *Xenopus* Suc1/Cks protein, is essential for the Cdc2-dependent phosphorylation of the anaphase-promoting complex at mitosis. *Genes Dev.* **12**, 2549–2559 (1998).
- Sudakin, V., Shteinberg, M., Ganoth, D., Hershko, J. & Hershko, A. Binding of activated cyclosome to p13<sup>suc1</sup>. Use for affinity purification. *J. Biol. Chem.* **272**, 18051–18059 (1997).
- Spruck, C. *et al.* A CDK-independent function of mammalian Cks1: targeting of SCF(Skp2) to the CDK inhibitor p27<sup>Kip1</sup>. *Mol. Cell* **7**, 639–650 (2001).
- Ganoth, D. *et al.* The cell-cycle regulatory protein Cks1 is required for SCF(Skp2)-mediated ubiquitinylation of p27. *Nat. Cell Biol.* **3**, 321–324 (2001).
- Harper, J.W. Protein destruction: adapting roles for Cks proteins. *Curr. Biol.* **11**, R431–R435 (2001).
- Bartek, J. & Lukas, J. p27 destruction: Cks1 pulls the trigger. *Nat. Cell Biol.* **3**, E95–E98 (2001).
- Bourne, Y. *et al.* Crystal structure and mutational analysis of the human Cdk2 kinase complex with cell cycle-regulatory protein CksHs1. *Cell* **84**, 863–874 (1996).
- Sitry, D. *et al.* Three different binding sites of Cks1 are required for p27-ubiquitin ligation. *J. Biol. Chem.* **277**, 42233–42240 (2002).
- Odaert, B. *et al.* Solution NMR study of the monomeric form of p13<sup>suc1</sup> protein sheds light on the hinge region determining the affinity for a phosphorylated substrate. *J. Biol. Chem.* **277**, 12375–12381 (2002).
- Schymkowitz, J.W., Rousseau, F., Wilkinson, H.R., Friedler, A. & Itzhaki, L.S. Observation of signal transduction in three-dimensional domain swapping. *Nat. Struct. Biol.* **8**, 888–892 (2001).
- Freire, E. Can allosteric regulation be predicted from structure? *Proc. Natl. Acad. Sci. USA* **97**, 11680–11682 (2000).
- Freire, E. The propagation of binding interactions to remote sites in proteins: analysis of the binding of the monoclonal antibody D1.3 to lysozyme. *Proc. Natl. Acad. Sci. USA* **96**, 10118–10122 (1999).
- Suel, G.M., Lockless, S.W., Wall, M.A. & Ranganathan, R. Evolutionarily conserved networks of residues mediate allosteric communication in proteins. *Nat. Struct. Biol.* **10**, 59–69 (2003).
- Lockless, S.W. & Ranganathan, R. Evolutionarily conserved pathways of energetic connectivity in protein families. *Science* **286**, 295–299 (1999).
- Seeliger, M.A., Schymkowitz, J.W., Rousseau, F., Wilkinson, H.R. & Itzhaki, L.S. Folding and association of the human cell cycle regulatory proteins CksHs1 and CksHs2. *Biochemistry* **41**, 1202–1210 (2002).
- Teichmann, S.A. The constraints protein-protein interactions place on sequence divergence. *J. Mol. Biol.* **324**, 399–407 (2002).
- Rousseau, F., Schymkowitz, J.W., Sanchez del Pino, M. & Itzhaki, L.S. Stability and folding of the cell cycle regulatory protein, p13<sup>suc1</sup>. *J. Mol. Biol.* **284**, 503–519 (1998).
- Brown, N.R. *et al.* Effects of phosphorylation of threonine 160 on cyclin-dependent kinase 2 structure and activity. *J. Biol. Chem.* **274**, 8746–8756 (1999).
- Schulman, B.A. *et al.* Insights into SCF ubiquitin ligases from the structure of the Skp1-Skp2 complex. *Nature* **408**, 381–386 (2000).
- Zheng, N. *et al.* Structure of the Cul1-Rbx1-Skp1-F boxSkp2 SCF ubiquitin ligase complex. *Nature* **416**, 703–709 (2002).
- Friedler, A. *et al.* A peptide that binds and stabilizes p53 core domain: chaperone strategy for rescue of oncogenic mutants. *Proc. Natl. Acad. Sci. USA* **99**, 937–942 (2002).
- Arvai, A.S., Bourne, Y., Hickey, M.J. & Tainer, J.A. Crystal structure of the human cell cycle protein CksHs1: single domain fold with similarity to kinase N-lobe domain. *J. Mol. Biol.* **249**, 835–842 (1995).
- Seeliger, M.A., Beward, S.E. & Itzhaki, L.S. Weak cooperativity in the core causes a switch in folding mechanism between two proteins of the Cks family. *J. Mol. Biol.* **325**, 189–199 (2003).